

Ringkern- Sicherheits- und Trenntransformator 25 VA bis 100 VA

toroidal- safety -and isolating transformer 25 VA up to 100 VA

Ringkern-Transformatoren
Befestigung mit Aufsnappvorrichtung
für Hutschienen TS 35

toroidal-transformers
mounting on mounting angles or for
mounting on rails TS 35



Bei Verwendung der alternativen Klemmen:
 $h = h + 20 \text{ mm}$

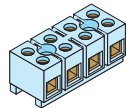

$h = h + 55 \text{ mm}$

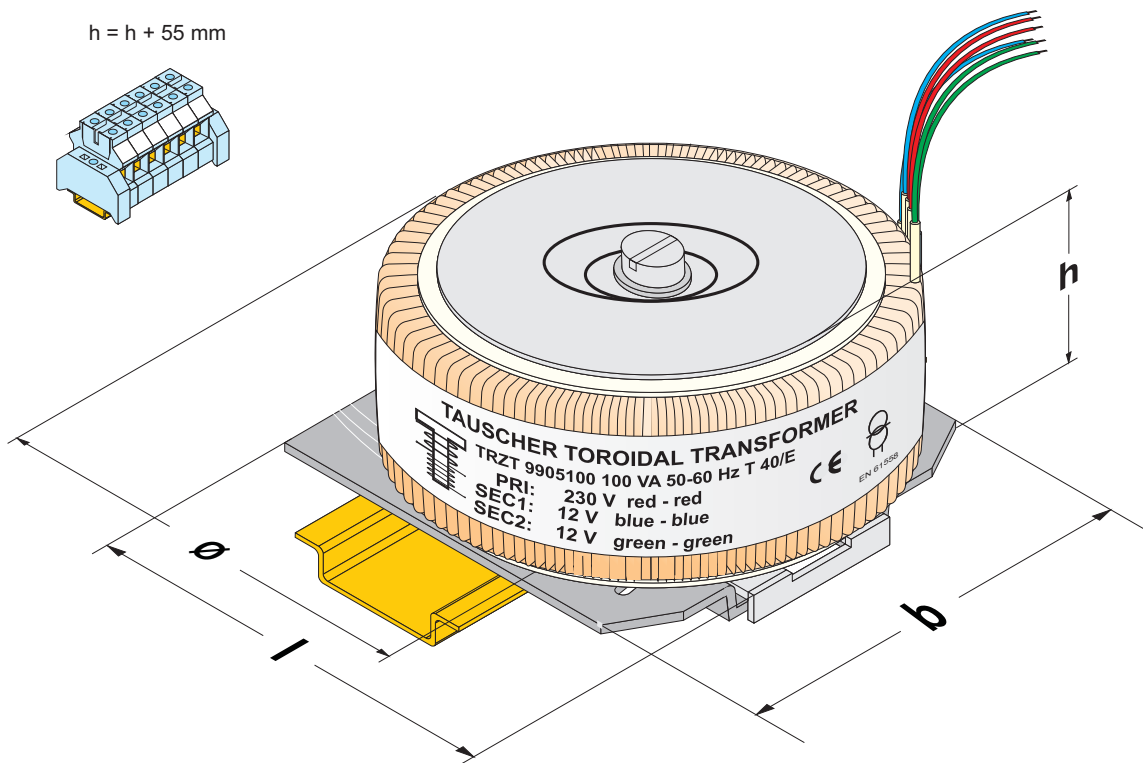
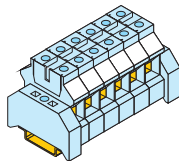

Typ type	Sekundär- leistung secondary power	Wirkungs- grad effi- ciency η	Leerlauf- strom noload- current $I_0 \pm 10\%$ U_0/U_L	Abmessungen / dimensions in mm			Kupfer- gewicht copper weight	Gesamt- gewicht total weight
				Ringkern \emptyset	h	l		
TRO.R.	25 VA	82%	6 mA	60	38	90	93,5	0,17 kg ca. 0,45 kg
TRO.R.	40 VA	86%	8 mA	69	50	90	93,5	0,25 kg ca. 0,75 kg
TRO.R.	50 VA	86%	8 mA	75	48	90	93,5	0,26 kg ca. 0,90 kg
TRO.R.	100 VA	90%	10 mA	90	48	90	93,5	0,45 kg ca. 1,40 kg

Technische Änderungen und Verbesserungen vorbehalten.
Alle Angaben sind Richtwerte,
Abweichungen können möglich sein.

Technical changes and optimisation reserved.
All details are guide values, variations are possible.
Other dimensions and technical changes on request.

Tauscher Transformatorenfabrik GmbH
Gewerbegebiet Neureut
D - 94078 Freyung

Tel.: +49 (0) 8551/91696-0
Fax: +49 (0) 8551/91696-198

info@tauscher.com
www.ringkerntrafo.com