

Datasheet transformer switching relay TSRLF

> Datasheet

Transformer Switching Relay | Type TSRLF



The TSRLF is a control module which can be used as a control element of a transformer switching relay when used in combination with external thyristors or semiconductor relays. Using the TSRLF transformers can be frequently switched. Applying a patented smooth switching procedure the TSRLF controls the connected control element so that one or more single phase transformers running in parallel can be operated from an idle state or loaded state without inrush current. Smooth switching procedure eliminates inrush.

Fields Of Application

The TSRLF can be used in frequently switched welding or filament transformers for industrial applications, plant construction or research.

Functions

> Smooth Switching Procedure

The TSRLF premagnetises the transformer prior to complete switching using unipolar voltage impulses. The strength of the premagnetisation is the same for all transformers and its value should amount to the turning point of the hysteresis curve. The width of the required voltage impulses must be matched the different transformer types, such as packet core transformers or toroidal mains transformers. The potentiometer TP1 in the TSRLF is used for this purpose (see adjustment instructions)

> Half-Wave-Failure-Recognition (Option)

Line voltage distortions such as half-wave failures can result in saturation currents larger than the inrush current in the the transformer. The TSRLF reacts to half-wave failures by immediately switching off before saturation currents arise, and then the smooth switching on operation is again resumed. In this manner triggering of the fuse can be avoided.

> Control Output (Option)

The control output can be used either to send a fully-on signal, or can be used to drive a bypass protection used to bridge the control element in the switched on state. DIP switch 2 is used to activate the control output. In bypass-protection mode, the TSRLF switches the control element after complete switching on as soon as the bypass protection is bridged. On switching off, the TSRLF switches the control element back on before the bypass-protection is switched off. In this manner wear of the contact used for switching is avoided.

> DIP-Switch

Using the DIP switch the following settings can be applied: Control input application - control output application (For details see the operating instructions)

Datasheet transformer switching relay TSRLF

Technical Details

(Switching-on procedure according to Patent No.: DE 42 17 866, EP 05 75 715 B1, US 005 517 380A)

Rated voltage Standard Option Option Option Option	230 V: 190 VAC - 260 VAC; Peak voltage max. 800 V 110 V: 95 VAC - 135 VAC; Peak voltage max. 600 V 400 V: 350 VAC - 450 VAC; Peak voltage max. 1200 V 500 V: 410 VAC - 560 VAC; Peak voltage max. 1600 V 90 VAC - 260 VAC; Peak voltage max. 800 V (Half-wave failure recognition not available, only with semiconductor relays)														
Frequency	45 - 65 Hz														
Overvoltage category	III														
Control element Standard:	Semiconductor relays quick action switching, 2,5 kV Test voltage between the control and load circuit. Characteristic quantities for the semiconductor relay: Open-circuit control voltage DC: $U_{320} = 5\text{ V}$ DC internal resistance: $R_{32} = 120\text{ Ohm}$ Maximum available control current: $I_{32} = 10\text{ mA}$ Maximum permissible switching on delay: $t_{\text{ein}} = 0,2\text{ ms}$ Maximum permissible switching-off delay: $t_{\text{aus}} = 0,25\text{ ms}$														
Option (Thyristors):	Triggering through Opto-Triacs across protection resistor R _{VG} inside TSRLF <table border="1"> <tr> <td>V_{rat}</td> <td>110 V</td> <td>230 V</td> <td>400 V</td> <td>500 V</td> </tr> <tr> <td>R_{VG}</td> <td>68 Ohm</td> <td>130 Ohm</td> <td>240 Ohm</td> <td>300 Ohm</td> </tr> </table> Characteristics of the Thyristors: Max. available Gate current: $I_{Gt} = 220\text{ mA}$ Max. permissible triggering delay: $t_{gd} = 0,2\text{ ms}$ Max. permissible release time: $t_q = 0,25\text{ ms}$ Gate cathode resistance: $R_{GK} = 120\text{ }\Omega / 0,25\text{ W}$ Gate cathode diode: $D_{GK} = \text{for example: 1N4004}$					V _{rat}	110 V	230 V	400 V	500 V	R _{VG}	68 Ohm	130 Ohm	240 Ohm	300 Ohm
V _{rat}	110 V	230 V	400 V	500 V											
R _{VG}	68 Ohm	130 Ohm	240 Ohm	300 Ohm											
Power supply failure	After a power supply failure $\geq 60\text{ms}$ smooth switching on take place when power is returned														
Option: Half-wave failure recognition	After a power supply failure $> 2\text{ms}$ smooth switching on take place when power is returned														
Turn-on delay	TP1 setting	on R	on P	Dimmer R	Dimmer P										
	Mains on with activated control input	ca. 0,88s	ca. 0,13s	ca. 0,93s	ca. 0,43s										
	Switching on using control input	ca. 0,23s	ca. 0,06s	ca. 0,33s	ca. 0,28s										
Turn-off delay	Switching off using control input:	Without bypass-protection:		ca. 0,03-0,05s											
		With bypass-protection:		ca. 0,33-0,35s											
Switching frequency	Unlimited														
Control input Standard:	Using an external make contact (Test voltage to earth 2,5kV) Contact voltage: 5V Contact current 14mA Connectors S1/ S2 are connected to the mains Using control voltage (Isolation voltage 2,5kV)														
Opto coupler input option:	Control voltage: 4- 32 VDC Control current: 1-12 mA														
Control output option:	Relay contact Max. switching power (ohmic load): 2000VA Max. switching voltage: 380VAC Max. switching current: 10A Rated load (ohmsche Load): 8A/250VAC, 5A/380VAC, 8A/24VDC Life time: Mechanical 20×10^6 Electrical 100×10^3														
Bypass-protection	Max. permissible response delay:	0,3s at 50Hz, 0,23s at 60Hz													
	Max. permissible release delay:	0,3s at 50Hz, 0,23s at 60Hz													
Ext. Potentiometer:	Resistance: 1-2,5 k Ohm, max. cable length 0,5m, U _{cw-ccw} = 5VDC														
For special functions	For special functions Potentiometer is connected to the mains (test voltage: 2,5kV)														
EMC (CE):	Interference immunity: EN 61000-6-2; Interference emission: EN 61000-6-3 To comply to the limits of the interference emission (crackle interference) the TSRLF may be switched on and off maximum five times per minute without external mains filtering..														
Connections Mains/load connections: Control input Control output Ext. potentiometer	Screw terminals, connection cross-section, 0.2 - 4mm ² , tightening torque 0.5-0.6Nm Spring terminals, connection cross-section 0.1-2mm ² Screw terminals, connection cross-section 0.2-4mm ² , tightening torque 0.5-0.6Nm Spring terminals, connection cross-section 0.1-0.5mm ²														
Fixture	- Quick connection to 35mm connection rails according to DIN EN 50 022 or DIN EN50035														
Type	- Wall mounting of the housing using two 4.5mm bore holes - Circuit board mounting (without housing) using three 3.2mm bore holes														
Housing: Circuit board:	Encapsulated, housing made from insulating material Open														
Cleanliness class	In the housing: 3, circuit board: 2														
Degree of protection	In the housing: IP20 circuit board: IP00														
Protection class	Protection class II														
Dimensions (LxWxH)	With housing: 98x88x35mm; Circuit board: 63,5x85x30mm														

Datasheet transformer switching relay TSRLF

Housing	Material ABS, Flammability class UL94 HB
Weight	0,2kg
Shock resistance	10g
Humidity max.	95%, no condensation
Ambient temperature	0°C to 60°C, special version: -20°C to +80°C
Storage temperature	-10°C to 70°C

Dimensions and Ordering Key

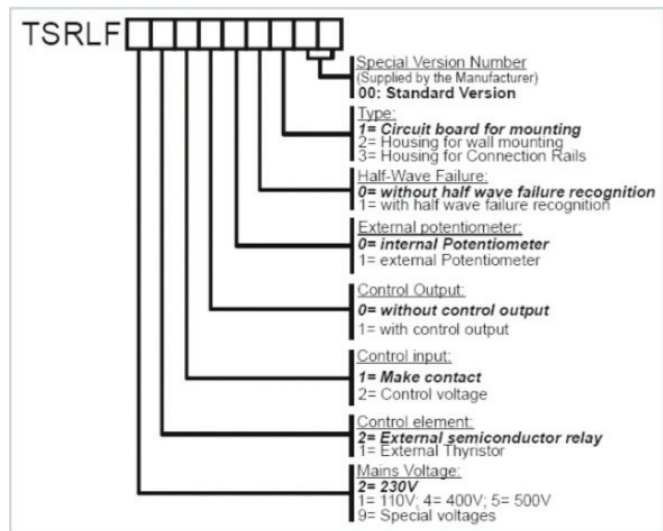
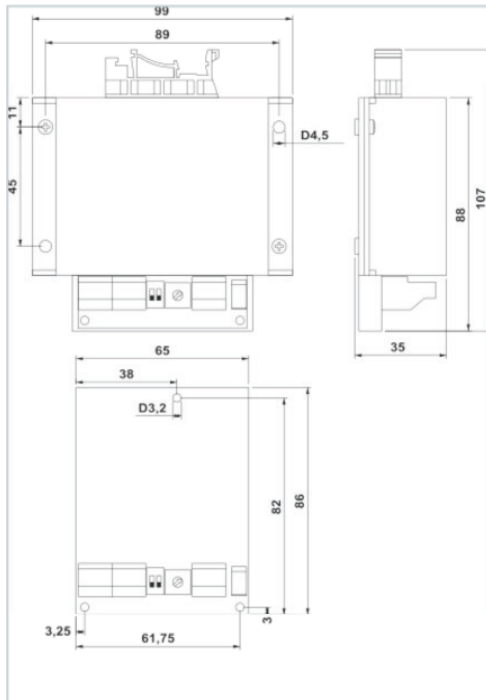

Fiels Of Application

Example 1:

The TSRLF module controls external Thyristors. The TSRLF has the option full on signalisation and control input for control voltage.

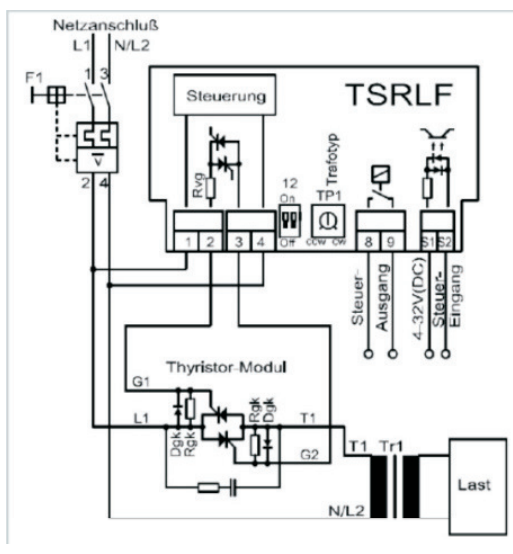

Example 2:

The TSRLF module controls an external Solid state relay with type of instantaneous switching. The TSRLF has the option bypass-contactor-control and Control input for an external closing contact.

